

Integrated Metal Detector Checkweigher MHR600UC

Technical Information

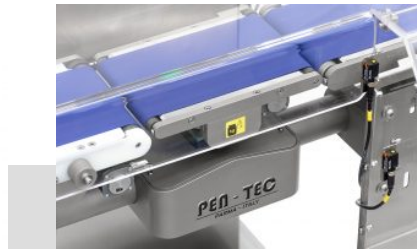
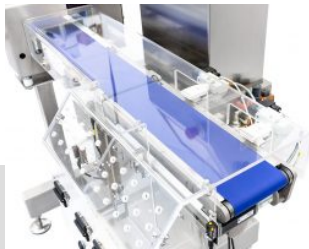

Ultra-compact Combi system high speed and performance

The integrated monoblock Metal Detector+Checkweigher unit series MHR-600/UC is designed to operate in extremely tiny spaces, where high detection performance of metal contaminants and weight must be guaranteed. The weighing group provides a system for the acquisition of high resolution weight which allows full compliance to the most stringent legal metrology requirements, also for extremely light products and high speed production. There are available: interconnection kits for the Industry 4.0, remote assistance modules and management and data collection software.

TECHNICAL FEATURES

- **Control Panel:** colour touch-screen 12"
- **Data Processing Electronics:** RISC Embedded FPGA
- **Self-learning System and Calibration:** Included
- **Metal Detector:** Multi-frequency, digital, with DSP filters
- **Data Collection Software:** Included through Ethernet and USB
- **Kit for Remote Assistance:** Included
- **Compliance Industry 4.0:** with Bidirectional Communicator
- **Conformity:** CE, MID, BRC, IFS, HACCP
- **Linear Speed:** up to 90 m/min
- **Maximum Speed:** up to 450 ppm
- **Conveyors Length Setup:** from 1.200 to 1.350 mm
- **Conveyor Width Setup:** 140 mm
- **Weight Range:** up to 600 g
- **Display Division:** 0,1 - 0,2 - 0,5 g
- **Protection Degree:** IP65
- **Motorization:** Brushless with planetary gearboxes
- **Structure:** Stainless Steel AISI304
- **Voltage and Power Absorption:** 110/230V AC 50/60Hz, L, N, PE - 500W

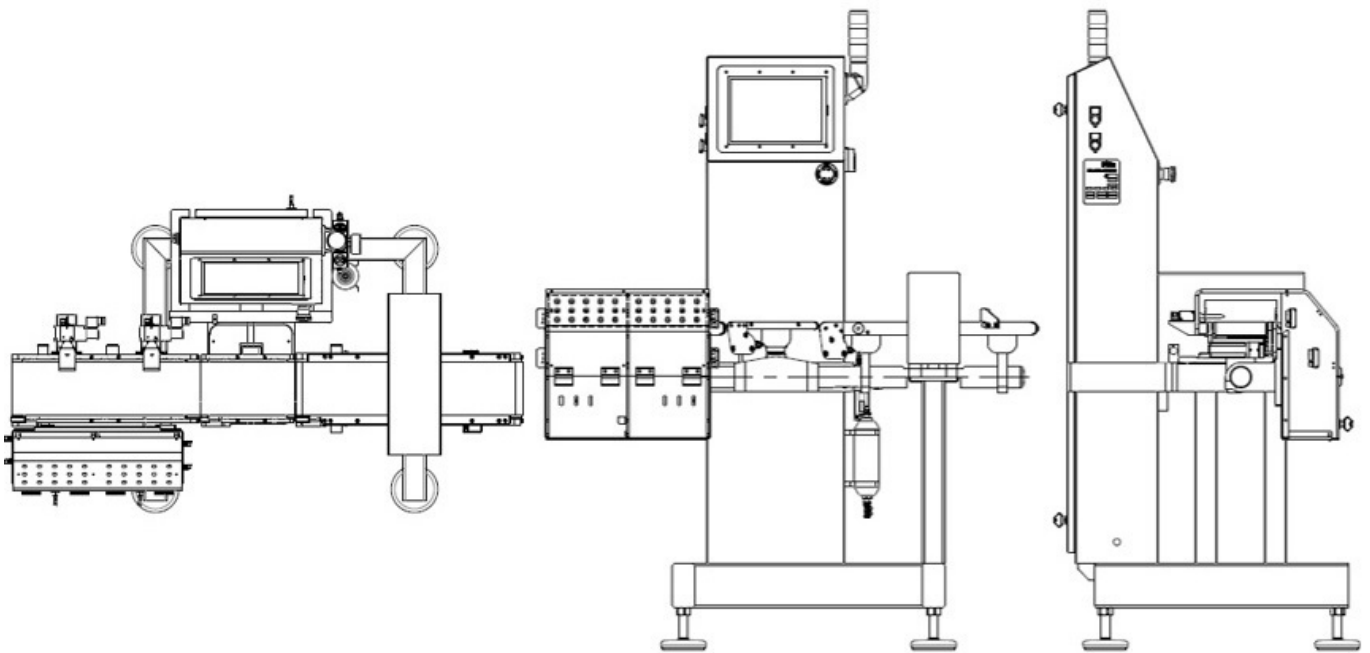

www.clavis-tec.com - www.pen-tec.it



Clavistec Srl:
info@clavis-tec.com
+39 0521 1477601

Pen-Tec Srl:
info@pen-tec.it
+39 0521 303412

[Facebook](#) [Linkedin](#)
[YouTube](#) [Instagram](#)

Via F. Santi, 3 43044 Lemignano di Collecchio PR (Italy)